

What did you say? (1)

Groups or Pairs

Student A:

Read the text below to everybody. (Step 1, Step 2, etc.)

Use checking words.



Are you ready?
Are you with me?
Are you OK?
OK so far?
Do you get it?
Do you follow me?
Do you understand?

Other Person/People:

Listen to Student A.

Do the actions that Student A tells you.

Use checking words.

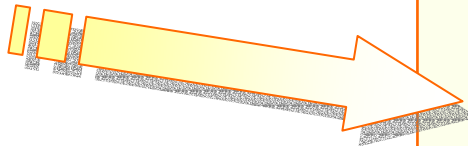

What did you say?
One more time, please.
Say it again, please.
I don't understand.
I don't get it.
Like this?
Is this OK?

Step 1 Are you ready?

Get a square piece of paper.

(Do you understand?)

Fold it in half diagonally.

(Are you with me?)

Make a crease. (OK so far?)

Turn the paper over.

(Have you got it?)

1.

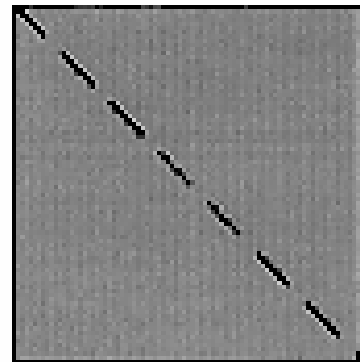

2.

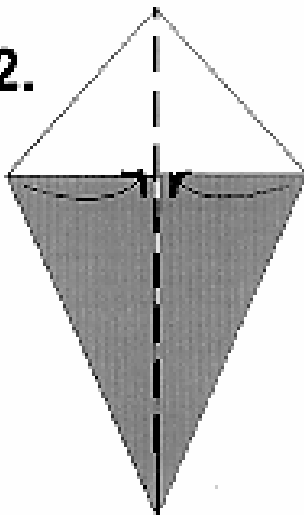

Step 2

Fold the corners to the center line.

(Do you understand?)

Make a crease. (Do you follow me?)

Turn the paper over.

3.

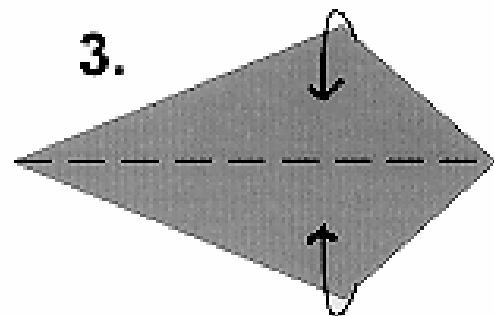

Step 3

Fold it in half along the center crease.

(Do you understand?)